

# SERIES 35-72-60730-2-5 Compliant



## 120 VAC Microprocessor-Based Direct Spark Ignition Control

F-35-72H, Revision AA  
September 2025

### FEATURES

- Safe start with DETECT-A-FLAME® flame sensing technology
- Custom pre-purge and inter-purge timings
- Single or three trials for ignition
- Local or remote flame sensing
- Thermostat/Power off reset
- Open board with standoffs or potted

### APPLICATIONS

- Commercial cooking
- Infrared burners
- Construction and agriculture heaters
- Other gas-fired appliances

### DESCRIPTION

The 35-72 is a 120 VAC direct spark ignition (DSI) control designed for use in all types of gas-fired appliances. The control uses a microprocessor circuit to provide precise, repeatable timing and operating sequences.

The optional UART communication offers advanced diagnostic data and connectivity with the Fenwal Connected Control series 05-50 Wi-Fi device or directly to OEM interface.

### EXPORT INFORMATION (USA)

Jurisdiction: EAR  
ECCN: EAR99

### AGENCY CERTIFICATIONS



ANSI Z21.20:22  
CSA-C22.2 No. 60730-2-5



### SPECIFICATIONS

|                                   |   |
|-----------------------------------|---|
| Input Power                       | 102 to 138 VAC, 50/60 Hz  |
| Input Current                     | 50 mA @120 VAC with gas valve relay energized (control only)                                  |
| Gas Valve                         | 1.5A max @ 120 VAC  |
| Operating Temperature             | -40°F to +176°F<br>(-40°C to +80°C)   |
| Storage Temperature               | -40°F to +185°F<br>(-40°C to +85°C)   |
| Flame Sensitivity                 | 1.0 µA minimum  |
| Flame Failure Response            | 0.8 seconds maximum   |
| Flame Detector Self-check Rate    | Once per second minimum   |
| Gas Types                         | Natural, LP, or manufactured  |
| Spark Rate                        | 50/60 sparks/sec (Line frequency)   |
| Size (LxWxH) with enclosure       | 5.38 x 2.53 x 2.35 inches<br>(13.67 x 6.43 x 5.97 cm)   |
| Moisture Resistance               | Conformal coated to operate non-condensing to 95% R.H. Module should not be exposed to water. |
| Ingress Protection                | Not rated, protection provided by appliance in which it is installed                          |
| Tries for Ignition                | One or three try versions available   |
| Trial for Ignition Periods        | 4, 7, 10, 15 seconds available  |
| Pre-purge and Inter-purge Timings | 0, 5, 15 or 25 seconds available  |
| Communications                    | Optional UART communications  |

## SEQUENCE OF OPERATION / FLAME RECOVERY / SAFETY LOCKOUT

### START UP - HEAT MODE

When a call for heat is received from the thermostat supplying 120VAC to L1, the control will reset, perform a self-check routine, and begin a pre-purge delay. Following the pre-purge period, the gas valve is energized and sparking commences for the Trial For Ignition (TFI) period.

When flame is detected during the TFI, the sparking process is terminated and the gas valve remains energized. The thermostat and burner flame are constantly monitored to assure proper system operation. When the thermostat is satisfied and the demand for heat ends, the gas valve is immediately de-energized.

### FAILURE TO LIGHT - LOCKOUT

#### SINGLE TRIAL MODEL

Should the burner fail to light, or a flame is not detected during the TFI period, the gas valve will de-energize and the control will go into lockout.

#### MULTI TRIAL MODEL

Should the burner fail to light or the flame is not detected during the TFI period, the gas valve will de-energize. The control will then go through an inter-purge delay before an additional ignition attempt. The control attempts two additional ignition trials before de-energizing the gas valve and entering lockout.

#### FLAME FAILURE - RE-IGNITION MODE

If the established flame signal is lost while the burner is operating, the control will respond within 0.8 seconds by immediately energizing the H.V. spark for the TFI period in an attempt to relight the flame. If the burner does not light within the TFI, the gas valve will immediately de-energize and single try models will enter lockout. On multi-try models, a new TFI sequence will begin after an inter-purge delay. Multi-try models perform two additional attempts to light the burner before de-energizing the gas valve and entering lockout. If the burner relights, normal operation resumes.

#### FLAME FAILURE-RECYCLE MODE

With the "Recycle After Loss of Flame" option, upon loss of flame, the gas valve is de-energized and the control proceeds to inter-purge before attempting to relight the flame. Multi-try models permit three tries for ignition including inter-purges. If the burner relights, normal operation resumes. If the burner does not relight, the control will enter lockout.

### LOCKOUT RECOVERY

Recovery from lockout requires a manual reset by either resetting the thermostat, or removing 120 VAC for a period of 5 seconds.

## DIAGNOSTIC LED FAULT CONDITIONS

| LED Indication | Fault Mode                  |
|----------------|-----------------------------|
| Steady On      | Internal Control Failure    |
| 1 Flash        | Airflow Fault               |
| 2 Flashes      | Flame without call for heat |
| 3 Flashes      | Ignition Lockout            |
| 5 Flashes      | Weak Flame                  |

## MOUNTING AND WIRING

The 35-72 control is not position sensitive and can be mounted vertically or horizontally. The control may be mounted on any surface and fastened with #6 sheet metal screws. Secure the control in an area that will experience a minimum of vibration and remain below the maximum ambient temperature of 176°F (80°C).

All connections should be made with UL Approved, 105°C rated, 18 gauge, stranded, .054" thick insulated wire. Refer to the appropriate wiring diagram when connecting the 35-72 to other components in the system.

|   |  |
|---|--|
| <br><b>CAUTION</b> | <p><b>Label all wires prior to disconnection when servicing or replacing controls. Replace with same Fenwal or customer part number only. Wiring errors can cause improper and dangerous operation. A functional checkout of a replacement control should always be performed.</b></p> |
|---|--|

|   |   |
|---|---|
| <br><b>CAUTION</b> | <p><b>The control must be mounted and located in a manner which protects components from exposure to water (dripping, condensate, spraying, rain). Any control that has been exposed to water must be replaced.</b></p> |
|---|---|

|   |   |
|---|---|
| <br><b>CAUTION</b> | <p><b>Proper disposal is required. Do not discard in trash; must be recycled.</b></p> |
|---|---|

|   |  |
|---|--|
| <br><b>WARNING</b> | <p><b>All wiring must be performed in accordance with both local and national electrical code, and by a trained technician. Wiring must be at least #18 AWG/AWM rated for 105°C or higher.</b></p> |
|---|--|

|   |   |
|---|---|
| <br><b>WARNING</b> | <p><b>This product uses voltages of shock hazard potential. Wiring and initial operation must be performed by a qualified service technician.</b></p> |
|---|---|

**WARNING** Operation outside specifications could result in failure of the Fenwal Controls product and other equipment with potential for injury to people and property.

**WARNING** **RISK OF EXPLOSION OR FIRE**  
 The control cannot be serviced by the user. If any control faults are detected, the control must be replaced by a qualified service personnel. Risk of explosion or fire can result if the control module has been opened or with any attempts to repair, voiding the warranty. Do not use aluminum wiring, as this can also lead to risk of fire.

### TERMINAL DESIGNATIONS

| Terminal                      | Description         | Pin Location                                      | Wire Color |
|-------------------------------|---------------------|---|------------|
| <b>Single Spark and Sense</b> |                     | <b>6-Pin Connector</b>                            |            |
| B. Gnd                        | Burner Ground       | 1   | Purple     |
| V1                            | Valve Power         | 2   | Brown      |
| L2                            | Line Neutral        | 3   | White      |
| L1                            | 120 VAC Input (Hot) | 4   | Black      |
| Not Used                      |                     | 5   |            |
| V2                            | Valve Neutral       | 6   | Yellow     |
| <b>Remote Flame Sense</b>     |                     | <b>7-Pin Connector (same as above plus pin 7)</b> |            |
| S1                            | Remote Flame Sensor | 7   | Gray       |

### TROUBLESHOOTING GUIDE

| Symptom   | Recommended Actions   |
|---|---|
| 1. Control does not start                           | A. Miswired<br>B. No 120VAC at L1<br>C. Fuse or circuit breaker fault<br>D. Faulty control  |
| 2. Valve on - no spark during TFI                   | A. Shorted electrode - establish 1/8-inch gap<br>B. Check high voltage cable<br>C. Miswired   |
| 3. Spark on - valve off                             | A. Valve coil open<br>B. Valve wire disconnected<br>C. Faulty control, check voltage at gas valve terminal V1   |
| 4. Flame okay during TFI - no flame sense after TFI | A. Check electrode position<br>B. Check high voltage wire<br>C. Poor ground at burner<br>D. Poor flame, check flame current<br>E. Check remote sensor wire on S1<br>F. Check for proper L1, L2 polarity |

### WIRING DIAGRAMS

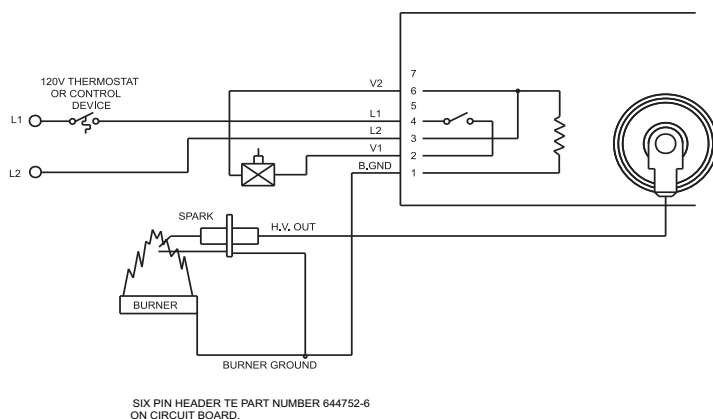

Figure 1. Local Sense

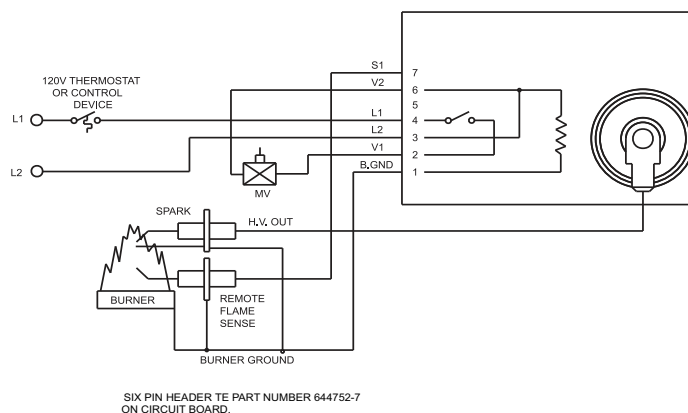
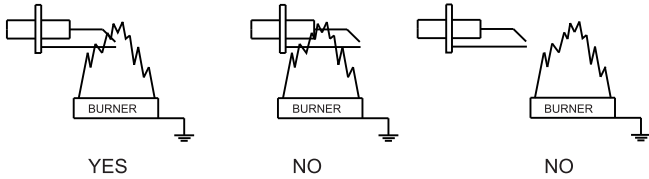

Figure 2. Remote Sense

## PROPER ELECTRODE LOCATION

Proper location of electrode assembly is important for optimum system performance. The electrode assembly should be located so that the tips are inside the flame envelope and about 1/2-inch (1.2 cm) above the base of the flame as shown:



### Notes:

- Ceramic insulators must not be in or close to the flame.
- Electrode assemblies must not be adjusted or disassembled. Electrodes are NOT field adjustable.
- Electrodes should have a gap spacing of  $0.125 \pm 0.031$  in ( $3.12 \pm 0.81$  mm), unless otherwise specified by the appliance manufacturer. If spacing is not correct, the assembly must be replaced.
- Exceeding temperature limits can cause nuisance lockouts and premature electrode failure.
- Electrodes must be located where they are not exposed during normal operation.

## HIGH VOLTAGE AND REMOTE SENSE CABLE REQUIREMENTS

The High Voltage (HV) Ignition Cable must meet a voltage rating of 25 KV and an insulation rating of 200°C. Length of 3 ft (0.9m) or less is recommended. Consult the factory for longer lengths.

Remote flame sense cable must meet a voltage rating of 250V and an insulation rating of 200°C. Length of 10 ft (3 m) or less is recommended. Consult the factory for longer lengths.

## COMMUNICATIONS

A communications option is available: Asynchronous serial with 5V single level swing. Consult the factory for details.

## FLAME CURRENT MEASUREMENT

Flame current is the current that passes through the flame from sensor to ground. The minimum flame current necessary to keep the system from lockout is 1.0  $\mu$ A. A good burner ground that matches the control ground is critical for reliable flame sensing.

## FLAME CURRENT CHECK: LOCAL SENSE

To measure flame current, disconnect input voltage, then insert a 0-50  $\mu$ A DC meter and capacitor in series with the spark electrode per Figure 3A. Reconnect input voltage and initiate call for heat. After sparking is complete and flame is established meter should read 1.0  $\mu$ A or higher while flame is established. If meter reads below "0" on the scale, meter leads are reversed. Disconnect power and reconnect meter leads for proper polarity.

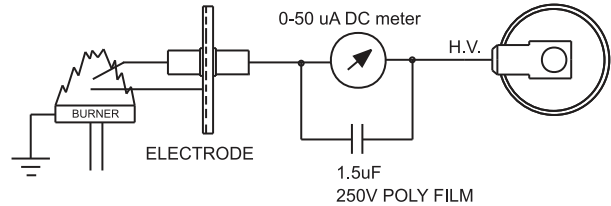

Figure 3A. Local Sense

## FLAME CURRENT CHECK: REMOTE SENSE

To measure flame current, disconnect input voltage, then insert a 0-50  $\mu$ A DC meter inline with flame sense wire per the Figure 3B. Reconnect input voltage and initiate call for heat. After sparking is complete and flame is established meter should read 1.0  $\mu$ A or higher while flame is established. If meter reads below "0" on the scale, meter leads are reversed. Disconnect power and reconnect meter leads for proper polarity.

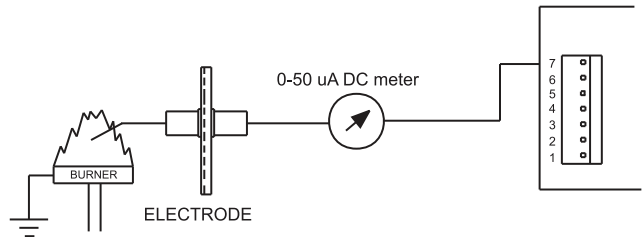

Figure 3B. Remote Sense

**Note:** All dimensions are in inches

## DIMENSIONS

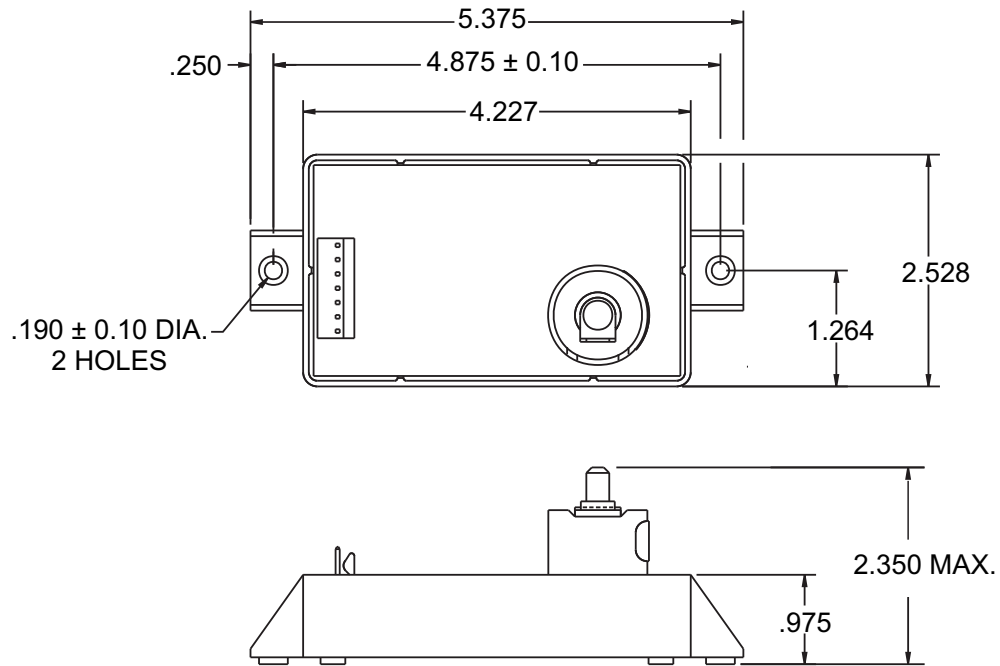

Figure 4. Potted (P/N: 35-72520X-XXX)

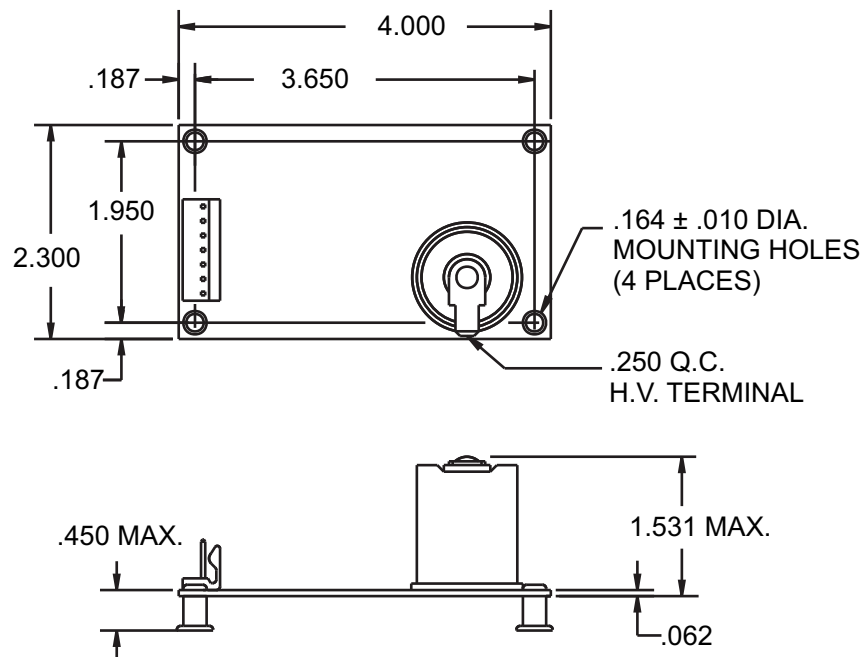

Figure 5. Integral Standoff (P/N: 35-72540X-XXX)

**Note:** All dimensions are in inches

# PART NUMBER CONFIGURATION

## SERIES 35-725 X 0 X - X X X

### Configuration and Wiring options

- 2 = Potted
  - 4 = Integral Standoffs
  - 5 = Communications
  - 8 = Aftermarket Kit
  - 9 = Special Configuration
- Multi-Pin Connector  
Multi-Pin Connector

An 8 or 9 in this location (i.e. 35-72 5 901 -113) indicates a special configuration. 9XX is a sequentially assigned part number and does not follow the standard part numbering configuration.

Consult Fenwal Controls for operating characteristics of this control.

### Trial for Ignition

- 1 = 4 Seconds
- 3 = 7 Seconds
- 5 = 10 Seconds
- 7 = 15 Seconds

### Inter-Purge

- 0 = None (Single Try Only)
- 1 = 15 Seconds
- 2 = 25 Seconds

### Pre-Purge

- 0 = None
- 1 = 15 Seconds
- 2 = 25 Seconds
- 5 = 5 Seconds

### Tries for Ignition, Flame Sense Method and Reset Method

- |                         |                              |
|-------------------------|------------------------------|
| 0 = 1 try, local sense  | Thermostat / power off reset |
| 1 = 1 try, remote sense | Thermostat / power off reset |
| 5 = 3 try, local sense  | Thermostat / power off reset |
| 6 = 3 try, remote sense | Thermostat / power off reset |

### EXPORT INFORMATION (USA)

Jurisdiction: EAR  
Classification: EAR99

This document contains technical data subject to the EAR.

Kidde Fire Systems, Kidde Fire Protection and Fenwal Controls branded products are created exclusively by Kidde-Fenwal, LLC, 400 Main St, Ashland, MA 01721, USA  
DETECT-A-FLAME is a registered trademark of Kidde-Fenwal, Inc., or its parents, subsidiaries, or affiliates. All trademarks are the property of their respective owners.



Fenwal Controls  
400 Main Street  
Ashland, MA 01721  
Tel: 800-FENWAL-1  
[Fenwal.com](http://Fenwal.com)

This literature is provided for informational purposes only. Kidde-Fenwal, LLC believes this data to be accurate, but it is published and presented without any guarantee or warranty whatsoever. Kidde-Fenwal, LLC assumes no responsibility for the product's suitability for a particular application. The product must be properly applied to work correctly. If you need more information on this product, or if you have a particular problem or question, contact KIDDE-FENWAL, INC., Ashland, MA 01721.