

SERIES 35-40

12/24 VDC Microprocessor-Based Direct Spark Ignition Control

F-35-40
March 2025

FEATURES

- Safe start with DETECT-A-FLAME® flame sensing technology
- Custom pre-purge and inter-purge timings*
- Single or three trials for ignition
- Green power LED
- System diagnostic LED
- Flame current test points
- Local or remote flame sensing
- Automatic reset**
- Non-volatile lockout with manual reset (optional)
- Digital alarm output
- UART communications (optional)
- RoHs compliant



APPLICATIONS

- Commercial cooking
- Commercial laundry
- Gas furnaces
- Water heaters
- Other gas-fired appliances

DESCRIPTION

The 35-40 is a 12/24 VDC direct spark ignition (DSI) control designed for use in all types of gas-fired appliances. The control uses a microprocessor circuit to provide precise, repeatable timing and operating sequences. High energy spark output and excellent flame sense characteristics provide reliable burner operation. On-board diagnostics with LED output makes troubleshooting easy and ensures safe and efficient operation.

Export Information (USA)

Jurisdiction: EAR
ECCN: EAR99

Agency Certifications



Design Certified to ANSI Z21.20-2014
CAN/CSA C22.2 No. 60730-2-5-14



CE Approved to EN 298:2022***



Australian Gas Safety certification to EN 298:2022
& AS 4625-2008

GSC 805642

* Pre-purge time cannot exceed inter-purge time on CE Approved models.

** Automatic reset is not allowed for CE Approved models.

*** EMC emission requirements shall be verified after incorporation of the burner control system into the end use appliance.

SPECIFICATIONS

Input Power	Control: 10-14 VDC or 20-28 VDC
Input Current	300 mA with gas valve relay energized (control only)
Gas Valve	5.0A max (continuous)
Alarm (lockout)	Open collector: 30 VDC max. Pull to GND: 100 mA max.
Operating Temperature	-40°F to +176°F (-40°C to +80°C)
Storage Temperature	-40°F to +185°F (-40°C to +85°C)
Flame Sensitivity	0.7 μ A minimum
Flame Failure Response or Reignition Time	0.8 seconds maximum
Flame Detector Self-check Rate	Once per second minimum
Gas Types	Natural, LP, or manufactured
Spark Rate	16 per second
Max. Size (LxWxH) with enclosure	5.3 x 3.3 x 1.8 inches (13.5 x 8.4 x 4.6 cm)
Moisture Resistance	Conformal coated to operate non-condensing to 95% R.H. Module should not be exposed to water
Ingress Protection	Not rated, protection provided by appliance in which it is installed
Tries for Ignition	One or three try versions available
Trial for Ignition Periods	4, 7, 10, 15 seconds available
Pre-purge and Inter-purge Timings	0, 15 or 30 seconds available

SEQUENCE OF OPERATION / FLAME RECOVERY / SAFETY LOCKOUT

Start Up - Heat Mode

When a call for heat is received from the thermostat supplying 12 or 24 VDC to TH, the green power LED will illuminate, the control will reset, perform a self-check routine, flash the diagnostic LED and begin a pre-purge delay. Following the pre-purge period, the gas valve is energized and sparking commences for the Trial For Ignition (TFI) period.

When flame is detected during the TFI, the sparking process is terminated and the gas valve remains energized. The thermostat and burner flame are constantly monitored to assure proper system operation. When the thermostat is satisfied and the demand for heat ends, the gas valve is immediately de-energized and the green LED turns off.

Failure to Light - Lockout

SINGLE TRIAL MODEL

Should the burner fail to light, or a flame is not detected during the TFI period, the gas valve will de-energize and the control will go into lockout. The diagnostic LED will indicate the fault code for ignition lockout.

MULTI TRIAL MODEL

Should the burner fail to light or the flame is not detected during the TFI period, the gas valve will de-energize. The control will then go through an inter-purge delay before an additional ignition attempt. The control attempts two additional ignition trials before de-energizing the gas valve and entering lockout. The diagnostic LED will indicate the fault code for ignition lockout.

FLAME FAILURE - RE-IGNITION MODE

If the established flame signal is lost while the burner is operating, the control will respond within 0.8 seconds by immediately energizing the H.V. spark for the TFI period in an attempt to relight the flame. If the burner does not light within the TFI, the gas valve will immediately de-energize and single try models will enter lockout. On multi-try models, a new TFI sequence will begin after an inter-purge delay. Multi-try models perform two additional attempts to light the burner before de-energizing the gas valve and entering lockout. If the burner relights, normal operation resumes.

FLAME FAILURE-RECYCLE MODE

With the "Recycle After Loss of Flame" option, upon loss of flame, the gas valve is de-energized and the control proceeds to inter-purge before attempting to relight the flame. Multi-try models permit three tries for ignition including inter-purges. If the burner relights, normal operation resumes. If the burner does not relight, the control will enter lockout.

Lockout Recovery

Recovery from lockout requires a manual reset by either resetting the thermostat, or removing power for a period of 5 seconds. On models with automatic reset, if the thermostat is still calling for heat after one hour, then the control will automatically reset and attempt to ignite the burner.

Some versions have an option for non-volatile lockout. In this case, only the external RESET input may be used to recover from an ignition lockout.

High Voltage and Remote Sense Cable Requirements

The HV Ignition Cable must meet a voltage rating of 25 KV and an insulation rating of 200 °C. Recommend length of 3ft (.9m) or less. Consult factory for longer lengths.

Remote flame sense cable must meet a voltage rating of 250V and an insulation rating of 200 °C. Recommended length of 10ft (3m) or less. Consult Factory for longer lengths.

MOUNTING AND WIRING

The Series 35-40 control is not position sensitive and can be mounted vertically or horizontally. The case may be mounted on any surface with #6 sheet metal screws.

 CAUTION	All wiring must be performed in accordance with both local and national electrical codes.
---	---

 CAUTION	Label all wires prior to disconnection when servicing controls. Wiring errors may cause improper and dangerous operation. A functional checkout of a replacement control should always be performed.
---	--

 WARNING	This product uses voltages of shock hazard potential. Wiring and initial operation must be performed by a qualified service technician.
---	---

 WARNING	Operation outside specifications could result in failure of the Fenwal product and other equipment with potential for injury to people and property.
--	--

Terminal Designations 10-pin (.156" Header)			
Name	Description	Alternate Use	Connection
ALARM	Lockout		Pin 1
POWER	Power (24 VDC)	(12 VDC)	Pin 2
RESET	Manual Reset		Pin 3
TH	Thermostat		Pin 4
GND	Valve Return		Pin 5
VALVE	Main Gas Valve		Pin 6
RX	Digital Output	UART RX	Pin 7
TX	Unused	UART TX	Pin 8
B. GND	Burner Ground		Pin 9
S1	Flame Sensor		Pin 10

For Wiring Harnesses, see the datasheet: "High Voltage Cable and Wiring Harnesses", P/N F-05-1000.

Wiring Diagrams - 35-40

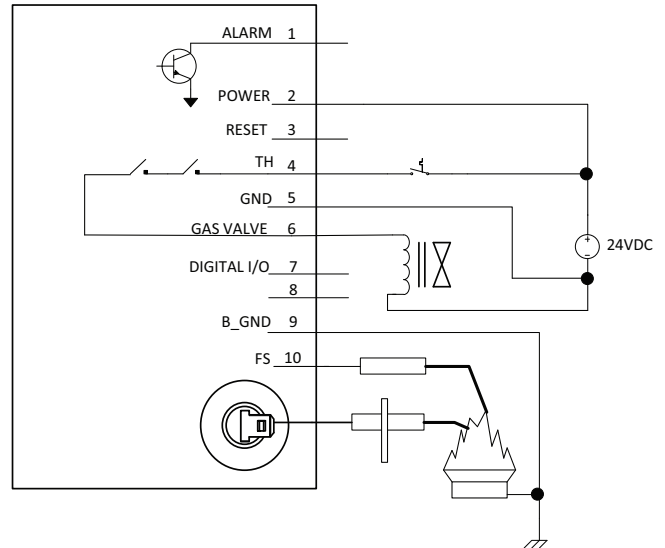

Figure 1. 24 VDC with Remote Sense

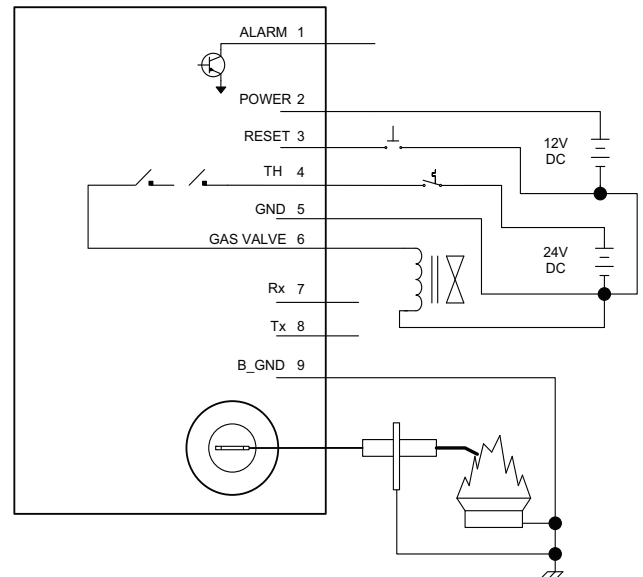

Figure 2. 12 VDC Power, 24 VDC Valve with Local Sense

TROUBLESHOOTING

Troubleshooting Guide	
Symptom	Recommended Actions
1. Control does not start, green LED is off	A. Miswired B. 12/24 VDC supply fault C. Fuse/circuit breaker fault D. No Thermostat Signal
2. Thermostat on - no spark	A. Miswired B. Faulty thermostat, no voltage at thermostat terminal TH C. Faulty control, check red LED for fault codes
3. Valve on - no spark during TFI	A. Shorted electrode - establish 1/8-inch gap B. Check high voltage cable C. Miswired
4. Spark on - valve off	A. Valve coil open B. Valve wire disconnected C. Faulty control, check voltage at gas valve terminal VALVE
5. Flame okay during TFI - no flame sense after TFI	A. Check electrode position B. Check high voltage wire C. Poor ground at burner D. Poor flame, check flame current

Fault Conditions - Red diagnostic LED	
LED Indication	Fault Mode
Steady On	Internal Control Failure
2 Flashes	Flame without call for heat
3 Flashes	Ignition Lockout

Note: During a fault condition, the LED will flash on for 1/4 second and off for 1/4 second as needed to indicate the fault code. The code will repeat every 3 seconds. Removing power from the control will clear the fault code.

Digital Output:

The diagnostic LED codes are also available as a 0 to 5 VDC signal on Pin 7. This output is current limited to 2 mA.

Internal Control Failure

If the control detects a software or hardware error, all outputs are turned off and the red LED displays a Steady On condition. If this condition persists after an attempt to restart, then the control must be replaced.

Proper Electrode Location

Proper location of electrode assembly is important for optimum system performance. The electrode assembly should be located so that the tips are inside the flame envelope and about 1/2-inch (1.2 cm) above the base of the flame as shown:

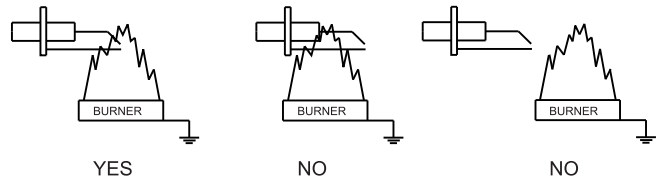

Notes:

- Ceramic insulators must not be in or close to the flame.
- Electrode assemblies must not be adjusted or disassembled. Electrodes are NOT field adjustable.
- Electrodes should have a gap spacing of 0.125 ± 0.031 in (3.12 ± 0.81 mm), unless otherwise specified by the appliance manufacturer. If spacing is not correct, the assembly must be replaced.
- Exceeding temperature limits can cause nuisance lockouts and premature electrode failure.
- Electrodes must be located where they are not exposed during normal operation.

Flame Current Measurement

Flame current is the current that passes through the flame from sensor to ground. To measure flame current, connect a True RMS or analog DC micro-ammeter to the FC+ and FC- terminals. Readings should be 1.0 μ A DC or higher. If the meter reads negative or below "0" on scale, meter leads are reversed. Reconnect leads with proper polarity.

Alternately, a Digital Voltmeter may be used to measure DC voltage between FC+ and FC- terminals. Each micro-amp of flame current produces 1.0 VDC. For example, 2.6 VDC equates to 2.6 μ A.

A good burner ground that matches the control ground is critical for reliable flame sensing.

DIMENSIONS

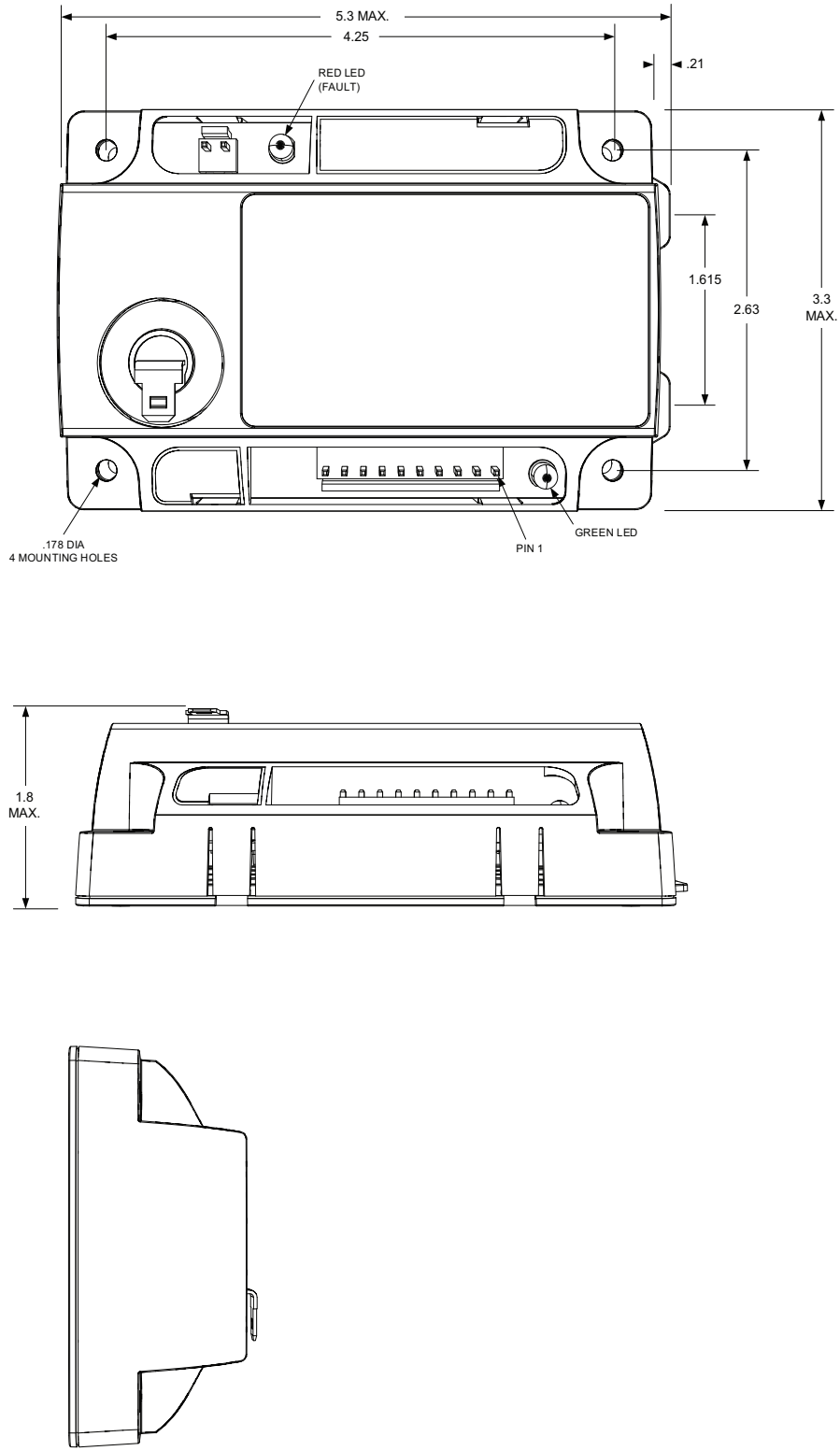

Figure 3. Standard Enclosure

Note: All dimensions are in inches

PART NUMBER CONFIGURATION

SERIES 35 - 40 X X X X - X X X

Voltage & Configuration

- 0 = 12 VDC Model
- 1 = 12 VDC with 24 VAC/VDC Thermostat/GV
- 2 = 12 VDC with Isolated GV Contacts
- 5 = 24 VDC Model
- 6 = 24 VDC with 12 VAC/VDC Thermostat/GV
- 7 = 24 VDC with Isolated GV Contacts

Product Designation

- 2 = Standard CE Approved Model*
- 3 = Special CE Approved Model*
- 5 = Multi-Pin Standard
- 9 = Special OEM Configuration

A 3 or 9 in this location (i.e. 35-40 0[901]-113) indicates a special configuration. 9XX is a sequentially assigned part number and does not follow the standard part numbering configuration.

Consult Fenwal for operating characteristics of this control.

* On CE Approved models, pre-purge time cannot exceed inter-purge time and automatic reset is not permitted.

Trial for Ignition Time

- 1 = 4 Seconds
- 3 = 7 Seconds
- 5 = 10 Seconds
- 7 = 15 Seconds

Inter-Purge Time

- 0 = None
- 1 = 15 Seconds
- 2 = 30 Seconds

Pre-Purge Time

- 0 = None
- 1 = 15 Seconds
- 2 = 30 Seconds

Tries for Ignition & Method of Flame Sense

- 0 = Single Try, Local Sense
- 1 = Single Try, Remote Sense
- 2 = Single Try, Local Sense with 1 Hour Automatic Reset
- 3 = Single Try, Remote Sense with 1 Hour Automatic Reset
- 5 = Three Tries, Local Sense
- 6 = Three Tries, Remote Sense
- 7 = Three Tries, Local Sense with 1 Hour Automatic Reset
- 8 = Three Tries, Remote Sense with 1 Hour Automatic Reset

Enclosure Configurations

- 0 = Noryl Gray Enclosure
- 1 = Integral Standoffs

EXPORT INFORMATION (USA)

Jurisdiction: EAR
Classification: EAR99
This document contains technical data subject to the EAR.

Kidde Fire Systems, Kidde Fire Protection and Fenwal Controls branded products are created exclusively by Kidde-Fenwal, LLC, 400 Main St, Ashland, MA 01721, USA
DETECT-A-FLAME is a registered trademark of Kidde-Fenwal, Inc., or its parents, subsidiaries, or affiliates. All trademarks are the property of their respective owners.



Fenwal Controls
400 Main Street
Ashland, MA 01721
Tel: 800-FENWAL-1
Fenwal.com

This literature is provided for informational purposes only. Kidde-Fenwal, LLC believes this data to be accurate, but it is published and presented without any guarantee or warranty whatsoever. Kidde-Fenwal, LLC assumes no responsibility for the product's suitability for a particular application. The product must be properly applied to work correctly. If you need more information on this product, or if you have a particular problem or question, contact KIDDE-FENWAL, INC., Ashland, MA 01721.

EU DECLARATION OF CONFORMITY

We

Company Name: Kidde-Fenwal Inc.
 Postal Address: 400 Main Street
 City and Post Code: Ashland, MA 01721
 Tel: 508-881-2000

Declare that the DoC is issued under sole responsibility and belongs to the following product:

Apparatus Model(s) Series 35-40, 35-53, 35-60, 35-61, 35-63, 35-608, 35-65, 35-66, 35-9X
 Type: Fitting
 Batch Number Date code and Revision Level Assigned per production lot, (YYWW RR)

Object of the Declaration:

Series 35-40, 12/24Vdc Direct Spark Automatic Gas Ignition Controllers
 Series 35-53, 12Vdc Direct Spark Automatic Gas Ignition Controllers
 Series 35-60, 35-61, 35-63, 35-608 24Vac Direct Spark Automatic Gas Ignition
 Series 35-65 & 35-66 24Vac Hot Surface Automatic Gas Ignition Controllers
 Series 35-9X Platform Ignition Module

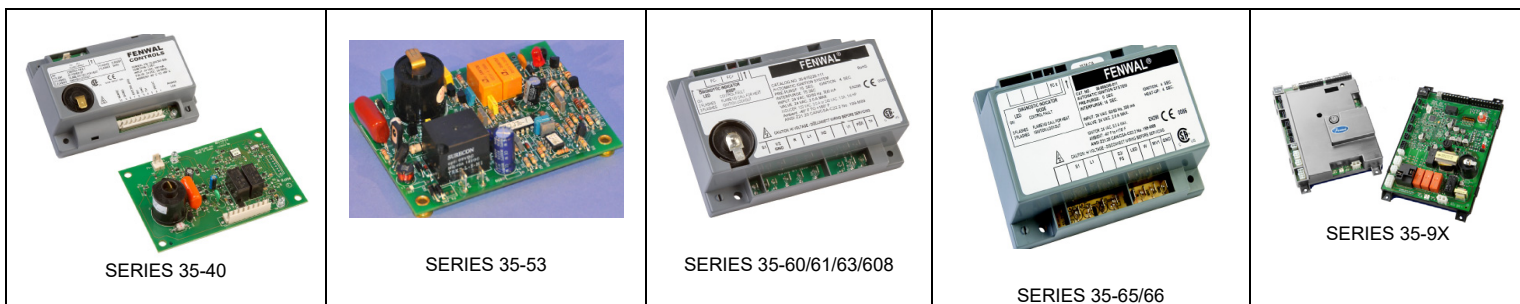

The object of the declaration described above is in conformity within the relevant union harmonization legislation:

Gas Appliance Regulation:	(EU) 2016/426	Low Voltage Directive:	2014/35/EC
EMC Directive:	2014/30/EC	Rohs	2011/65/EU

The following harmonized standards and technical specifications have been applied:

EN298:2022: Automatic Burner Control systems for Burners and appliances burning gaseous or liquid fuels.
EN13611:2019: Safety and control devices for Gas Burners and Gas burning appliances – General Requirements.

Name of Notified Body & Number: BSI Group, 2797, EU Type Examination Certification

Notified Body Certificate No.:	Series 35-40:	CE682407
	Series 35-53	CE682404
	Series 35-60/61/63/608	CE682405
	Series 35-65/66	CE682406
	Series 35-9x	CE690652

Surveillance Audit Notified Body: BSI Group

For copies of the Installation Instructions and the EU DoC, got to www.fenwalcontrols.com, - Document Library - Data sheets.

Paul Finn

Kidde-Fenwal, Inc. Ashland, MA USA	29 August 2024	Paul Finn, Certification Engineer
Place of Issue:	Date of Issue	Name

**NOTICE: READ THE INSTRUCTIONS
BEFORE USE. THESE CONTROLS SHALL
BE INSTALLED IN ACCORDANCE WITH
THE RULES IN FORCE**

**FOR A COPY OF THE INSTALLATION
INSTRUCTIONS AND THE EU DoC GO TO
WWW.FENWALCONTROLS.COM**