

SERIES 35-23

230 VAC Microprocessor-Based Direct Spark Intermittent Pilot Ignition Control

F-35-63
November 2025

FEATURES

- Safe start with DETECT-A-FLAME® flame sensing technology
- Inducer blower control and airflow switch monitoring
- Single or three trials for ignition
- System diagnostic LED
- Flame current test points
- Local or remote flame sensing
- Automatic reset**
- Alarm output (normally closed contact)

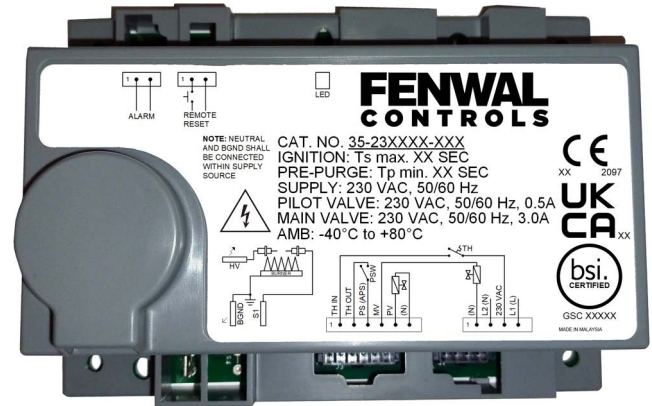

APPLICATIONS

- Gas furnaces
- Boilers
- Commercial cooking
- Water heaters
- Other gas-fired appliances

DESCRIPTION

The 35-23 is a 230 VAC intermittent pilot (spark-to-pilot) ignition control. The control uses a microprocessor circuit to provide precise, repeatable timing and operating sequences. On-board diagnostics with LED output makes troubleshooting easy and ensures safe and efficient operation.

Export Information (USA)

Jurisdiction: EAR
ECCN: EAR99

Agency Certifications



CE Approved to EN 298:2022***



Australian Gas Safety certification to EN 298:2022 & AS 4625-2008

* Pre-purge time cannot exceed inter-purge time on CE Approved models.

** Automatic reset is not allowed for CE Approved models.

*** EMC emission requirements shall be verified after incorporation of the burner control system into the end use appliance.

SPECIFICATIONS

Input Power	187V to 264V at 50/60Hz
Line Voltage	187V to 264V at 50/60Hz (L1 & IND contacts only)
Input Current	0.25 A maximum @ 230VAC 50Hz, 25°C
Pilot Gas Valve	0.5 A max @ 230 VAC
Main Gas Valve	1 A max @ 230 VAC
Operating Temperature	-40°F to +176°F (-40°C to +80°C)
Storage Temperature	-40°F to +185°F (-40°C to +85°C)
Flame Sensitivity	0.7 µA minimum
Flame Failure Response	0.8 seconds maximum
Flame Detector Self-check Rate	Once per second minimum
Gas Types	Natural, LP, or manufactured
Spark Rate:	25 sparks/sec
Size (LxWxH) with enclosure	5.69 x 3.94 x 1.87 inches (14.45 x 10.01 x 4.75 cm)
Moisture Resistance	Conformal coated to operate non-condensing to 95% R.H. Module should not be exposed to water
Ingress Protection	IP-20 (with cover)
Tries for Ignition	One or three try versions available
Trial for Ignition Periods	5 Sec maximum
Pre-purge and Inter-purge Timings	0, 15 or 30 seconds available
Post-purge Time	0, 30 or 60 seconds available
Alarm	Dry Contact Programmable 1A at 24VAC - 230VAC / 30VDC
Fuse	Non-replaceable
Reset	Volatile & Non-Volatile lockout with manual reset (optional)

SEQUENCE OF OPERATION / FLAME RECOVERY / SAFETY LOCKOUT

Power Up / Stand By

35-23 has the option for full time power or powered when 230Vac is applied to TH. Upon applying power or TH, the control will reset, perform a self-check routine, flash the diagnostic LED and enter the thermostat scan state.

Start Up - Heat Mode

When a call for heat is received from the thermostat supplying 230VAC to TH/W, the control begins a pre-purge delay. Following the pre-purge period, the pilot gas valve is energized and sparking commences for the Trial For Ignition (TFI) period. The main gas valve remains de-energized until the pilot flame is detected.

When the pilot flame is detected during TFI, the sparking process is terminated and the main gas valve is energized. The thermostat and pilot burner flame are constantly monitored to assure proper system operation. When the thermostat is satisfied and the demand for heat ends, the pilot and main valves are immediately de-energized.

Failure to Light - Lockout

SINGLE TRIAL MODEL

Should the pilot burner fail to light or the pilot flame is not detected during the TFI period, the pilot valve will de-energize and the control will go into lockout. The LED will indicate the fault code for ignition lockout.

MULTI TRIAL MODEL

Should the pilot burner fail to light or the pilot flame is not detected during the first TFI period, the pilot valve will de-energize. The control then goes through an inter-purge delay before an additional ignition attempt. The control attempts two additional ignition trials before de-energizing the pilot valve and entering lockout. The LED will indicate the fault code for ignition lockout.

FLAME FAILURE-RE-IGNITION MODE

If the established pilot flame signal is lost while the burner is operating, the control will respond within 0.8 seconds by de-energizing the main gas valve and energizing the H.V. spark for the TFI period in an attempt to relight the pilot burner. If the pilot burner does not light within the TFI, the pilot gas valve will immediately de-energize and single try models will enter lockout. On multi-try models, a new TFI sequence will begin after an inter-purge delay. Multi-try models perform two additional attempts to light the burner before de-energizing the gas valves and entering lockout. If the pilot burner relights, normal operation resumes.

FLAME FAILURE-RECYCLE MODE





With the "Recycle after Loss of Flame" option, upon loss of pilot flame, the pilot and main gas valves are de-energized and the control proceeds to inter-purge before attempting to relight the pilot flame. Multi-try models permit three tries for ignition including inter-purges. If the pilot burner relights, normal operation resumes. If the pilot burner does not relight, the control will enter lockout.

Lockout Recovery

Recovery from lockout requires a manual reset by either resetting the thermostat, or removing 230 VAC for a period of 5 seconds. On models with automatic reset, if the thermostat is still calling for heat after one hour, then the control will automatically reset and attempt to ignite the burner.

MOUNTING AND WIRING

The Series 35-63 is not position-sensitive and can be mounted vertically or horizontally. The case may be mounted on any surface with #6 sheet metal screws. The control also supports direct mounting to a standard NEC 4-in. junction box.

	All wiring must be performed in accordance with both local and national electrical codes.
	Label all wires prior to disconnection when servicing controls. Wiring errors may cause improper and dangerous operation. A functional checkout of a replacement control should always be performed.
	This product uses voltages of shock hazard potential. Wiring and initial operation must be performed by a qualified service technician.
	Operation outside specifications could result in failure of the Fenwal product and other equipment with potential for injury to people and property.

Terminal Designations		
Terminal	I/O	Description
J1	Pin 1: N	4-Pin Molex Microfit Mate-n-Lok Connector P/N 43650-0418
	Pin 2: L2 (N)	
	Pin 3: 230VAC TH Out	
	Pin 4: L1 (L)	
J3	Pin 1: TH In	6-Pin Molex Microfit Mate-n-Lok Connector P/N 43650-0618
	Pin 2: TH Out	
	Pin 3: Open	
	Pin 4: IND	
	Pin 5: V1	
	Pin 6: (N)	
J2 (Optional)	Pin 1: Alarm Mains	2-Pin Molex Microfit Mate-n-Lok Connector P/N 43650-0218
	Pin 2: Alarm Load	
J4 (Optional)	Pin 1 & 2: Manual Reset	2-Pin Molex Header 0.025 Square, 0.1 Center P/N: 22-23-2021
HV	Hi-Voltage	0.25 in. Quick Connect
FS	Remote-Sense	0.25 in. Quick Connect
GND	Ground	0.25 in. Quick Connect

Wiring Diagrams - 35-63

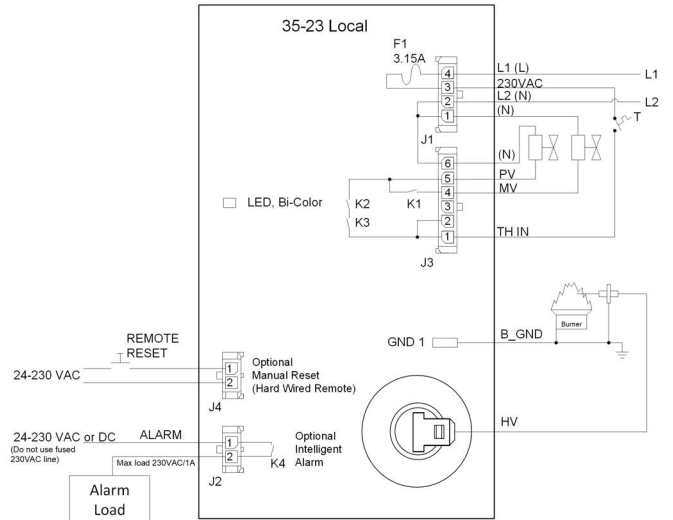

Figure 1. Local Sense

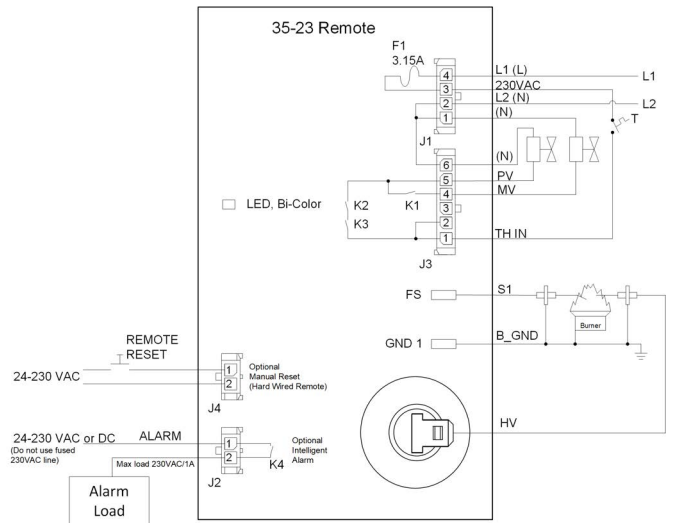

Figure 2. Remote Sense

Note: L2 must be connected to ground within the service panel

High Voltage and Remote Sense Cable Requirements

The HV Ignition Cable must meet a voltage rating of 25 KV and an insulation rating of 200 °C. Recommend length of 3ft (.9m) or less. Consult factory for longer lengths.

Remote flame sense cable must meet a voltage rating of 250V and an insulation rating of 200 °C. Recommended length of 10ft (3m) or less. Consult Factory for longer lengths.

TROUBLESHOOTING

Troubleshooting Guide	
Symptom	Recommended Actions
1. Control does not start	A. Miswired B. 24 VAC transformer fault C. Fuse circuit breaker fault D. Faulty control, check LED for fault codes
2. Thermostat on - no spark	A. Miswired B. Faulty thermostat, no voltage at thermostat terminal TH/W C. Faulty control, check LED for fault codes
3. Blower on - no TFI after purge delay	A. Miswired B. Flame fault C. Airflow fault (check voltage at PSW) D. Faulty control (check voltage between L1 & IND)
4. Valve on - no spark during TFI	A. Shorted electrode - establish 1/8-inch gap B. Check high voltage cable C. Miswired
5. Spark on - valve off	A. Valve coil open B. Valve wire disconnected C. Faulty control, check voltage at gas valve terminal V1
6. Flame okay during TFI - no flame sense after TFI	A. Check electrode position B. Check high voltage wire C. Poor ground at burner D. Poor flame, check flame current

Bi-Color LED Codes

Red LED Fault Conditions	
LED Indication	Fault Mode
Steady On	Internal Control Failure
1 Flash	Airflow Fault
2 Flashes	Flame without call for heat
3 Flashes	Ignition Lockout

Green LED Diagnostics	
LED Indication	Fault Mode
Steady On	Idle Mode
Slow Flash	Call for Heat
Fast Flash	Burn Mode

Note: During a fault condition, the LED will flash on for 1/4 second and off for 1/4 second as needed to indicate the fault code. The code will repeat every 3 seconds. Removing power from the control will clear the fault code.

Internal Control Failure

If the control detects a software or hardware error, all outputs are turned off and the LED displays a Steady On condition. If this condition persists after an attempt to restart, then the control must be replaced.

Flame Fault

If at any time the gas valve fails to completely close and maintains a flame, the flame sense circuit will detect it and energize the inducer blower. Should the valve later close completely removing the flame signal, the inducer blower will be turned off following the optional post purge period.

Proper Electrode Location

Proper location of electrode assembly is important for optimum system performance. The electrode assembly should be located so that the tips are inside the flame envelope and about 1/2-inch (1.2 cm) above the base of the flame as shown:

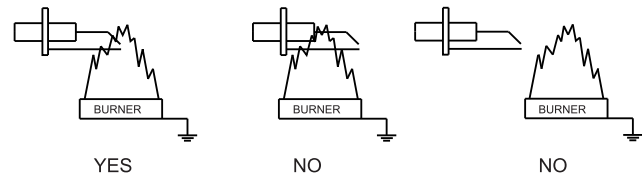

Notes:

- Ceramic insulators must not be in or close to the flame.
- Electrode assemblies must not be adjusted or disassembled. Electrodes are NOT field adjustable.
- Electrodes should have a gap spacing of 0.125 ± 0.031 in (3.12 ± 0.81 mm), unless otherwise specified by the appliance manufacturer. If spacing is not correct, the assembly must be replaced.
- Exceeding temperature limits can cause nuisance lockouts and premature electrode failure.
- Electrodes must be located where they are not exposed during normal operation.

DIMENSIONS

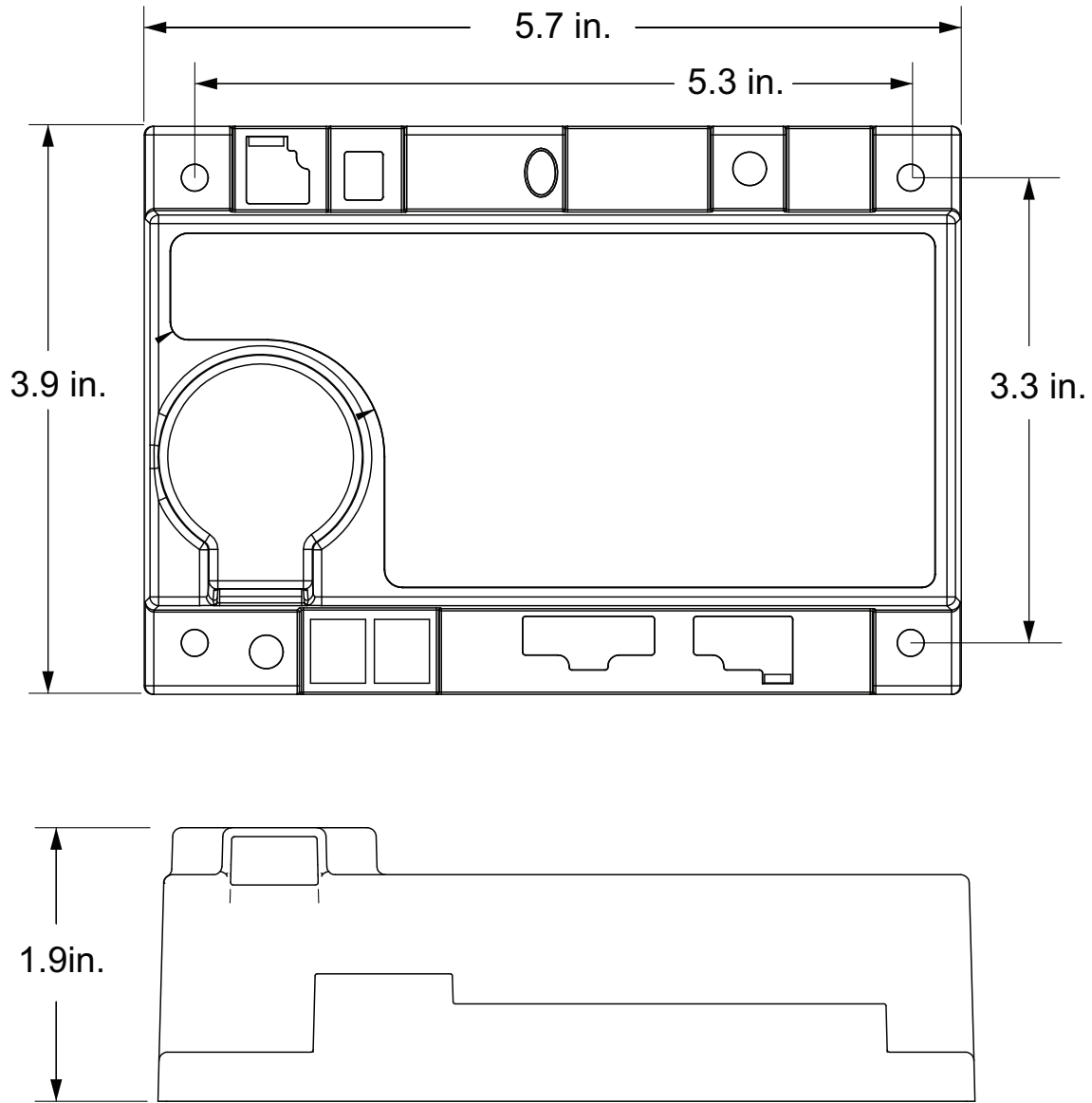

Note: All dimensions are in inches.

Figure 3. Standard Enclosure

PART NUMBER CONFIGURATION

35 – 2 X X X X X – X X X

Description

TRIAL FOR IGNITION

- 0 = NONE
- 1 = 4 SECONDS
- 2 = 5 SECONDS
- 3 = 7 SECONDS
- 4 = 10 SECONDS
- 5 = 15 SECONDS
- 6 = 30 SECONDS
- 7 = 60 SECONDS
- 8 = 90 SECONDS

INTER-PURGE

- 0 = NONE
- 1 = 15 SECONDS
- 2 = 30 SECONDS
- 3 = 45 SECONDS
- 4 = 4 MINUTES

PRE-PURGE

- 0 = NONE
- 1 = 15 SECONDS
- 2 = 30 SECONDS
- 3 = 45 SECONDS
- 4 = 4 MINUTES

TRY FOR IGNITION & FLAME SENSE

- 0 = SINGLE TRY, LOCAL SENSE
- 1 = SINGLE TRY, REMOTE SENSE
- 2 = THREE TRY, LOCAL SENSE
- 3 = THREE TRY, REMOTE SENSE
- 4 = SINGLE TRY, LOCAL SENSE – MANUAL RESET
- 5 = SINGLE TRY, REMOTE SENSE – MANUAL RESET
- 6 = THREE TRY, LOCAL SENSE – MANUAL RESET
- 7 = THREE TRY, REMOTE SENSE – MANUAL RESET
- 9 = SPECIAL, ADVANCED OPTION ID

POST-PURGE (35-21 Only)

- 0 = NONE
- 1 = 15 SECONDS
- 2 = 30 SECONDS
- 3 = 60 SECONDS
- 4 = 90 SECONDS
- 5 = 4 MINUTES
- 9 = SPECIAL, ADVANCED OPTION ID

COMMUNICATIONS

- 0 = NONE
- 9 = SPECIAL, ADVANCED OPTION ID

ENCLOSURE & HV TRANSFORMER

- 0 = NORYL ENCLOSURE HORIZONTAL QC (IP20)
- 1 = INTEGRAL STAND OFFS, HORIZONTAL OR VETICAL QC (IP00)
- 2 = INTEGRAL STAND OFFS, RAJA (IP00)

SERIES & FIELD TERMINALS

- 0 = DIRECT SPARK
- 1 = DIRECT SPARK W/FORCED DRAFT
- 3 = DIRECT SPARK, INTERMITTENT PILOT

EXPORT INFORMATION (USA)

Jurisdiction: EAR
Classification: EAR99

This document contains technical data subject to the EAR.

This literature is provided for informational purposes only. Kidde-Fenwal, LLC believes this data to be accurate, but it is published and presented without any guarantee or warranty whatsoever. Kidde-Fenwal, LLC assumes no responsibility for the product's suitability for a particular application. The product must be properly applied to work correctly. If you need more information on this product, or if you have a particular problem or question, contact KIDDE-FENWAL, LLC, Ashland, MA 01721.

fenwalcontrols.com
508.881.2000

Kidde Fire Systems, Kidde Fire Protection and Fenwal Controls branded products are created exclusively by Kidde-Fenwal, LLC.
All trademarks are the property of their respective owners. All products are the property of their respective owners.

 **KiddeFenwal**

400 Main Street, Ashland, MA 01721
P/N: F-35-63 Rev. AB | kiddefenwal.com | 508-881-2000
2025© Kidde-Fenwal LLC | All Rights Reserved

EU DECLARATION OF CONFORMITY

We

Company Name: Kidde-Fenwal, LLC
 Postal Address: 400 Main Street
 City and Post Code: Ashland, MA 01721
 Tel: 508-881-2000

Declare that the DoC is issued under sole responsibility and belongs to the following product:

Apparatus Model(s) Series 35-40, 35-53, 35-60, 35-61, 35-63, 35-608, 35-65, 35-66, 35-9X
 Type: Fitting
 Batch Number Date code and Revision Level Assigned per production lot, (YYWW RR)

Object of the Declaration:

Series 35-20, 35-21, 35-23 230Vac Direct Spark Automatic Gas Ignition Controllers
 Series 35-40, 12/24Vdc Direct Spark Automatic Gas Ignition Controllers
 Series 35-53, 12Vdc Direct Spark Automatic Gas Ignition Controllers
 Series 35-60, 35-61, 35-63, 35-608 24Vac Direct Spark Automatic Gas Ignition
 Series 35-65 & 35-66 24Vac Hot Surface Automatic Gas Ignition Controllers
 Series 35-9X Platform Ignition Module

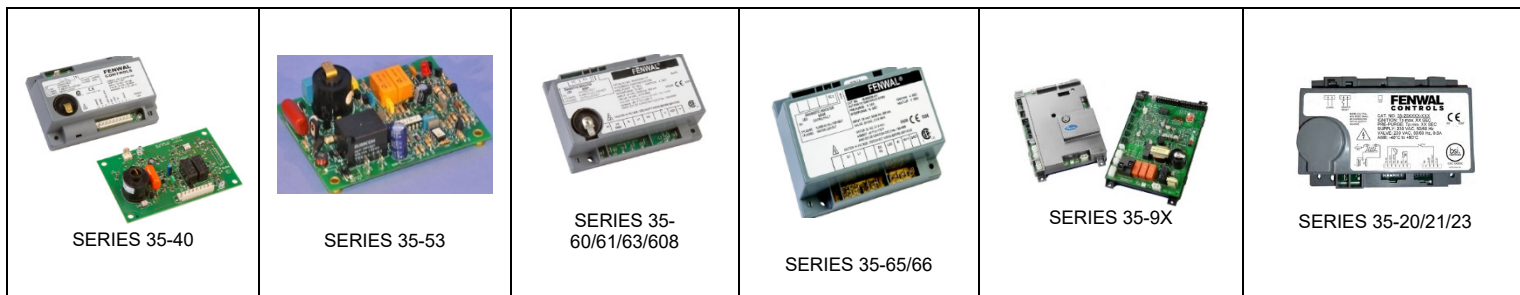

The object of the declaration described above is in conformity within the relevant union harmonization legislation:

Gas Appliance Regulation:	(EU) 2016/426	Low Voltage Directive:	2014/35/EC
EMC Directive:	2014/30/EC	Rohs	2011/65/EU

The following harmonized standards and technical specifications have been applied:

<u>EN298:2022:</u>	Automatic Burner Control systems for Burners and appliances burning gaseous or liquid fuels.
<u>EN13611:2019:</u>	Safety and control devices for Gas Burners and Gas burning appliances – General Requirements.

Name of Notified Body & Number: BSI Group, 2797, EU Type Examination Certification

Notified Body Certificate No.:	Series 35-20/21/23	CE828701
	Series 35-40:	CE682407
	Series 35-53	CE682404
	Series 35-60/61/63/608	CE682405
	Series 35-65/66	CE682406
	Series 35-9x	CE690652

Surveillance Audit Notified Body: BSI Group

For copies of the Installation Instructions and the EU DoC, got to www.fenwalcontrols.com, - Document Library - Data sheets.

Paul Finn

Kidde-Fenwal, LLC. Ashland, MA USA
 Place of Issue:

9 Sept 2025
 Date of Issue

Paul Finn, Certification Engineer
 Name