

Fire and Overheat Detector

F-03-001
June 2024

DESCRIPTION

The Fire/Overheat Detector is a normally open device that helps to monitor fire and overheat conditions. It can be used in locations with high ambient temperatures.

The detector is made from welded stainless steel and is completely sealed. It is not repairable and cannot be disassembled. The detector is set to a specific alarm temperature when it is made at the factory and the temperature cannot be adjusted.

The detector electrically connects to its related equipment through two terminal posts with internal threads. Stainless steel screws attach the wiring from the related equipment to the two terminals. The detector mechanically attaches to the monitored area by 3/4-14 National Pipe Thread (NPT) located on the head of the detector. The temperature setting of the detector is marked on the hex body. See Figure 1 in the Outline Drawing for 17343-124 section for details.



PART NUMBERS AND TEMPERATURE SETTINGS

| Fenwal P/N | Setting* ^{***} | Color |
|------------|-------------------------|--------|
| 17343-124 | 140°F | None |
| 17343-124 | 325°F | Red |
| 17343-124 | 425°F | Green |
| 17343-124 | 600°F | Orange |
| 17343-124 | 725°F | Gray |

* Specify heat setting when ordering.
**All temps. ± 25°F (± 13.89°C)

CONSTRUCTION

Hermetically sealed switch with glass to metal seals.

| Set Point Temperature | Max Continuous Ambient Temperature |
|-----------------------|------------------------------------|
| 140°F (60°C) | 40°F (38°C) |
| 325°F (163°C) | 225°F (149°C) |
| 600°F (316°C) | 500°F (260°C) |
| 725°F (385°C) | 625°F (329°C) |

| | |
|-----------------------|---|
| Insulation Resistance | 20 Megohm @ 500 Vdc, terminals to shell |
| Dielectric Strength | 500 VAC, 1 minute, terminals to shell |
| Contact Rating | 0.5 AMP at 125 Vdc |

The following details are shown on a detector head:

- Customer Part Number
- Customer Code
- Part Number: **17343-124**
- Date Code: XXYY (where XX = year, YY = week)

AGENCY APPROVALS FOR 17343-124

| Agency | File Number | Rating | Agency Marking |
|-------------------------------|-------------------------|---|----------------|
| CSA | 1641537 | Class I, Division 1, Group B, C, D | CSA |
| UL | E139663 | Class I, Division 1, Group B, C, D | UL |
| UL | S4968 | Heat Actuated Device for Special Applications | |
| ATEX | ITS03ATEX41211U | II 3G Ex nC IIC Gc | Ex |
| IEC Ex | IECEXETL12.0008U | Ex nC IIC | |
| CE (Intertek) | 101404110BOX-001 | Control Circuit Devices and Switching Elements Electromechanical Control Circuit | CE |
| Federal State Institute VNIPO | GOST R C-US.ПБ01.В02201 | Safety Requirements for a Heat Detector | TR |
| Korean | 14-KB4BO-0749U | Fire/Overheat Detector Ex nC IIC | KCS |

HANDLING AND STORAGE

- Take precautions to ensure that the shell and threads are not subject to damage.

INSTALLATION

Note: Local Authorities Having Jurisdiction (AHJ) should be consulted before installation.

1. The 17343-124 detector must be mounted into an IP 54 Rated enclosure that complies with the appropriate requirements for Equipment Group II Category 3 applications. Enclosures must have a 3/4 NPT opening to mount the detector.
2. Thread the unit into the 3/4 NPT opening at least 5 full turns and torque to 20 foot pounds (27 N m).
3. Ensure that enclosures are grounded.
4. Connect system wiring to the detector's terminals per applicable electrical codes using 8-32 UNC 2A stainless steel slotted hex head screws with integral washer (provided).

OUTLINE DRAWING FOR 17343-124

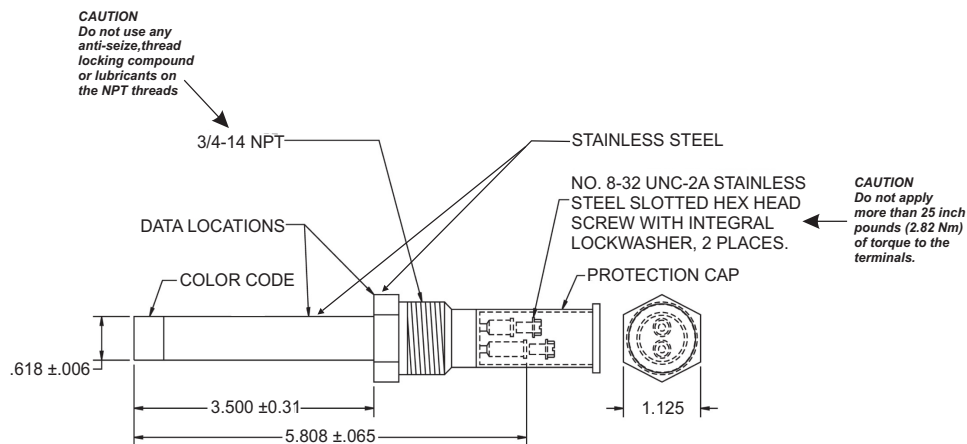

Figure 1. Fire/Overheat Detector

OPTIONAL OFFERING: EXPLOSION PROOF BOX ASSEMBLY

The Explosion Proof Box Assembly includes part number 17343-124 Heat Detector and Field wire Terminal housing. The Explosion Proof Box Assembly is available in right hand option (03-017343-127) and left hand option (03-017343-126) as shown in Figure 2 below.

The Assembly 03-017343-127 / 03 017343-126 is designed for installation in potentially explosive atmospheres and is certified with the following ratings:



II 3 G Ex nA nC IIC T3 Gc
IEC Ex ETL 12.0015X
-20°C ≤ Ta ≤ 198°C
ITS12ATEX47636X



Korean Cert # 14-KB4BO-0668X
Ex nC IIC T3

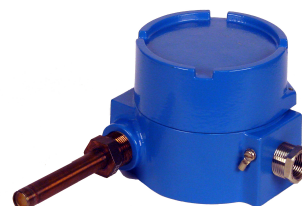

Note: For additional requirements please refer to Series 03-017343-12X Installation Instructions for Fire/Overheat Detector Assembly.

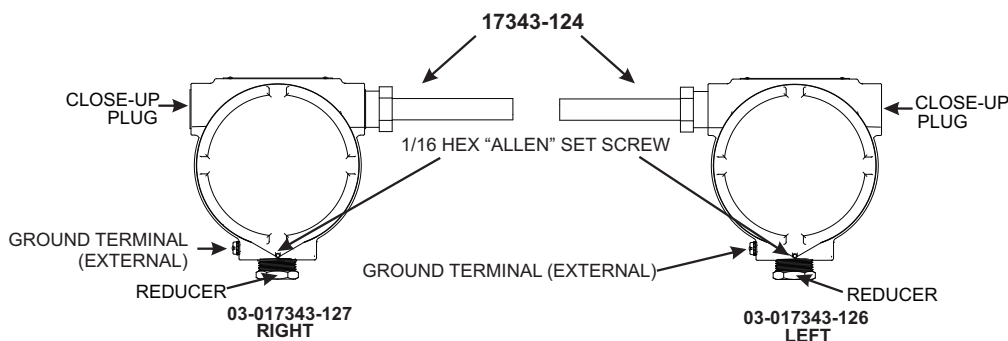

Figure 2. Explosion Proof Box Outline Drawing for 17343-126/127

This literature is provided for informational purposes only. KIDDE-FENWAL, INC. assumes no responsibility for the product's suitability for a particular application. The product must be properly applied to work correctly. If you need more information on this product, or have a particular problem or question, contact KIDDE-FENWAL, INC.

